

NRG 0800H-3600H

Reversible air/water heat pump

Cooling capacity 194,9 ÷ 962,3 kW
 Heating capacity 209,6 ÷ 991,9 kW

- High efficiency also at partial loads
- Reduced amount of refrigerant
- Night mode



DESCRIPTION

Reversible outdoor heat pumps for the production of chilled/heated water designed to satisfy the needs of residential and commercial buildings, or for industrial applications.

The base, the structure and the panels are made of galvanized steel treated with polyester paint RAL 9003.

VERSIONS

- ° Standard
- A High efficiency
- E Silenced high efficiency
- L Standard silenced

FEATURES

Operating field

Working at full load up to -15 °C outside air temperature in winter, and up to 49 °C in summer. Hot water production up to 60 °C (for more details refer to the technical documentation).

Unit with 2/3 cooling circuits

Unit with 2/3 refrigerant circuits designed to provide maximum efficiency at full load, ensuring high efficiency at partial loads also and ensuring continuity in case one of the circuits stops.

Refrigerant HFC R32

The environmental impact of the units is reduced considerably owing to the last generation R32 refrigerant.

Combining a reduced refrigerant load with a low global warming potential (GWP), these units boast low equivalent CO₂ values.

The leak detector is supplied as per standard.

Use refrigerant fluid R32, whose classification according to ISO 817 is A2L (non-toxic, odourless and slightly flammable refrigerant).

New condensing Coils

The whole range uses copper - aluminium condensation coils with reduced diameter rows, allowing a lower quantity of gas to be used compared to traditional coils.

Electronic expansion valve

The possibility to use electronic expansion valve, offers significant benefits, especially when the chiller is working with partial loads, increasing the energy seasonal efficiency of the unit.

Option integrated hydronic kit

An optional, integrated hydronic kit containing the main hydraulic components, to obtain a solution that allows you to save money and to facilitate installation.

It is available in different configurations with storage tank or with fixed pumps also inverter.

CONTROL PCO⁵

Microprocessor adjustment, with 7", touch screen keyboard, which allows to navigate intuitively among the various screens, allowing to modify the operating parameters and graphically view the progress of some variables in real time and the adjustment includes complete management of the alarms and their log.

- Possibility to control two units in a Master-Slave configuration (from size 0800 to 2400)
- The presence of a programmable timer allows functioning time periods and a possible second set-point to be set.
- The temperature control takes place with the integral proportional logic, based on the water output temperature.
- **Floating HP control:** available for all models with an inverter fan or DCPX. Thanks to continuous fan modulation, unit operation is optimised in every working position in cooling mode. The result is enhanced machine energy efficiency with partial loads.
- **"EASYLOG" data logger as per standard:** allows all operating data read by the pCO5 to be stored on an SD card.
- **Night Mode:** it is possible to set a silenced operation profile. Perfect for night operation since it guarantees greater acoustic comfort in the evenings, and a high efficiency in the time of greater load.

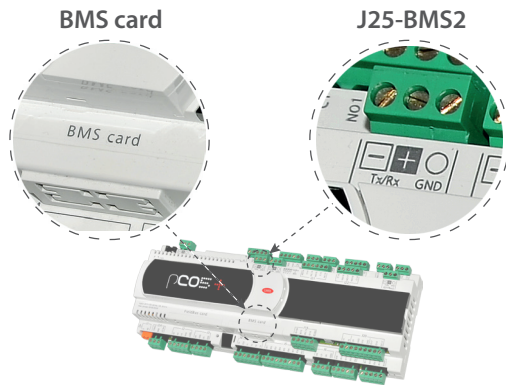

In the 'BMS card' port, the compatible accessories are:

- AER485P1
- AERBACP
- MULTICHILLER_EVO + AER485P1

In the 'J25-BMS2' port, the compatible accessories are:

- AERNET

Note:

- "BMS card" and "J25-BMS2" are two ports on the unit's control board. Only one accessory can be connected to each port.
- An 'EASYLOG' diagnostic device may be present in port 'J25-BMS2'; possibly disconnect it to connect the accessory AERNET.
- **For other requirements, please contact the company.**

INTEGRATED SOLUTION

The "integrated solution" concept has been implemented in the system architecture, consisting in an integrated and streamlined control of compressors and electronic valve.

This solution allowed a variety of new features to be introduced, such as:

- **Low Superheat Control:** Progressive superheating reduction in conditions of stability. This allows to increase energy performance: both in modulation and in full load conditions;
- **DLT control:** Control of electronic valve at discharge temperature in certain operating conditions. This is demonstrated in an enhanced reliability of the control and a considerable expansion of the machine's operating range, especially in heating mode.

ACCESSORIES

AER485P1: RS-485 interface for supervision systems with MODBUS protocol.

AERBACP: Ethernet communication Interface for protocols Bacnet/IP, Modbus TCP/IP, SNMP

AERNET: The device allows the control, the management and the remote monitoring of a Chiller with a PC, smartphone or tablet using Cloud connection. AERNET works as Master while every unit connected is configured as Slave (max. 6 unit); also, with a simple click is possible to save a log file with all the connected unit datas in the personal terminal for post analysis.

FL: Flow switch.

MULTICHILLER_EVO: Control, switch-on and switch-off system of the single chillers where multiple units are installed in parallel, always ensuring constant flow rate to the evaporators.

PGD1: Allows you to control the unit at a distance.

AVX: Spring anti-vibration supports.

DCPX: Device for condensation temperature control, with continuous speed modulation of fans by using a pressure transducer.

FACTORY FITTED ACCESSORIES

DRE: Electronic device for peak current reduction.

RIF: Power factor correction. Connected in parallel to the motor allowing about 10% reduction of input current.

GP_: Anti-intrusion grid kit

T6: Double safety valve with exchange cock, both on the high and low pressure branches.

ACCESSORIES COMPATIBILITY

Model	Ver	0800	0900	1000	1100	1200	1400	1600	1800	2000	2200	2400	2600	2800	3000	3200	3400	3600
AER485P1	°A,E,L
AERBACP	°A,E,L
AERNET	°A,E,L
FL	°A,E,L
MULTICHILLER_EVO	°A,E,L
PGD1	°A,E,L

Condensation control temperature

Ver	0800	0900	1000	1100	1200	1400	1600	1800	2000
°	DCPX161	DCPX161	DCPX161	DCPX163	DCPX163	DCPX163	DCPX163	DCPX163	DCPX165
A	DCPX161	DCPX163	DCPX163	DCPX163	DCPX165	DCPX165	DCPX165	DCPX165	DCPX167
E,L	As standard	As standard	As standard	As standard	As standard	As standard	As standard	As standard	As standard

Ver	2200	2400	2600	2800	3000	3200	3400	3600
°	DCPX167	DCPX167	DCPX174	DCPX174	DCPX175	DCPX175	DCPX175	DCPX175
A	DCPX169	DCPX169	DCPX174	DCPX175	DCPX175	DCPX175	DCPX176	DCPX176
E,L	As standard	As standard	As standard	As standard	As standard	As standard	As standard	As standard

Antivibration

Ver	0800	0900	1000	1100	1200	1400	1600	1800	2000	2200	2400	2600	2800	3000	3200	3400	3600
Integrated hydronic kit: 00																	
°	AVX1151	AVX1151	AVX1151	AVX1153	AVX1153	AVX1153	AVX1153	AVX1154	AVX1163	AVX1163	AVX1163	AVX1167	AVX1167	AVX1171	AVX1171	AVX1171	AVX1171
A,L	AVX1151	AVX1153	AVX1153	AVX1153	AVX1154	AVX1154	AVX1154	AVX1156	AVX1159	AVX1159	AVX1167	AVX1171	AVX1171	AVX1171	AVX1171	AVX1169	AVX1169
E	AVX1153	AVX1154	AVX1154	AVX1154	AVX1156	AVX1156	AVX1159	AVX1161	AVX1161	AVX1165	AVX1165	AVX1169	AVX1173	AVX1173	AVX1173	AVX1175	AVX1175
Integrated hydronic kit: AA, AB, AC, AD, AE, AF, AG, AH, AI, AJ, BA, BB, BC, BD, BE, BF, BG, BH, BI, BJ, CA, CB, CC, CD, CE, CF, CG, CH, CI, CJ, KA, KB, KC, KD, KE, KF, KG, KH, KI, KJ																	
°	AVX1152	AVX1152	AVX1152	AVX1152	AVX1152	AVX1152	AVX1152	AVX1155	AVX1157	AVX1157	AVX1157	AVX1168	AVX1168	AVX1172	AVX1172	AVX1172	AVX1172
A,L	AVX1152	AVX1152	AVX1152	AVX1152	AVX1155	AVX1155	AVX1155	AVX1157	AVX1157	AVX1160	AVX1160	AVX1168	AVX1172	AVX1172	AVX1172	AVX1170	AVX1170
E	AVX1152	AVX1155	AVX1155	AVX1155	AVX1157	AVX1157	AVX1160	AVX1162	AVX1162	AVX1166	AVX1166	AVX1170	AVX1174	AVX1174	AVX1174	AVX1176	AVX1176
Integrated hydronic kit: DA, DB, DC, DD, DE, DF, DG, DH, DI, DJ, IA, IB, IC, ID, IE, IF, IG, IH, II, IJ, JA, JB, JC, JD, JE, JF, JG, JH, JI, JJ, PA, PB, PC, PD, PE, PF, PG, PH, PI, PJ																	
°	AVX1151	AVX1151	AVX1151	AVX1153	AVX1153	AVX1153	AVX1153	AVX1154	AVX1163	AVX1163	AVX1163	AVX1167	AVX1167	AVX1171	AVX1171	AVX1171	AVX1171
A,L	AVX1151	AVX1153	AVX1153	AVX1153	AVX1154	AVX1154	AVX1158	AVX1156	AVX1156	AVX1164	AVX1164	AVX1167	AVX1171	AVX1171	AVX1171	AVX1169	AVX1169
E	AVX1153	AVX1154	AVX1154	AVX1154	AVX1156	AVX1156	AVX1159	AVX1161	AVX1161	AVX1165	AVX1165	AVX1169	AVX1173	AVX1173	AVX1173	AVX1175	AVX1175

Device for peak current reduction

Ver	0800	0900	1000	1100	1200	1400	1600	1800	2000
° ,A,E,L	DRENRG0800	DRENRG0900	DRENRG1000	DRENRG1100	DRENRG1200	DRENRG1400	DRENRG1600	DRENRG1800	DRENRG2000

A grey background indicates the accessory must be assembled in the factory

Ver	2200	2400	2600	2800	3000	3200	3400	3600
° ,A,E,L	DRENRG2200	DRENRG2400	DRENRG2600	DRENRG2800	DRENRG3000	DRENRG3200	DRENRG3400	DRENRG3600

A grey background indicates the accessory must be assembled in the factory

Power factor correction

Ver	0800	0900	1000	1100	1200	1400	1600	1800	2000
° ,A,E,L	RIFNRG0800	RIFNRG0900	RIFNRG1000	RIFNRG1100	RIFNRG1200	RIFNRG1400	RIFNRG1600	RIFNRG1800	RIFNRG2000

A grey background indicates the accessory must be assembled in the factory

Ver	2200	2400	2600	2800	3000	3200	3400	3600
° ,A,E,L	RIFNRG2200	RIFNRG2400	RIFNRG2600	RIFNRG2800	RIFNRG3000	RIFNRG3200	RIFNRG3400	RIFNRG3600

A grey background indicates the accessory must be assembled in the factory

Anti-intrusion grid

Ver	0800	0900	1000	1100	1200	1400	1600	1800	2000	2200	2400	2600	2800	3000	3200	3400	3600
°	GP2VN	GP2VN	GP2VN	GP3G	GP3G	GP3G	GP3G	GP4G	GP5G	GP5G	GP5G	GP11G	GP10G	GP12G	GP12G	GP12G	GP12G
A,L	GP2VN	GP3G	GP3G	GP3G	GP4GM	GP4GM	GP4GM	GP5G	GP5G	GP6G	GP6G	GP11G	GP12G	GP12G	GP12G	GP13G	GP13G
E	GP3G	GP4GM	GP4GM	GP4GM	GP5GM	GP5GM	GP6G	GP7G	GP7G	GP8G	GP8G	GP13G	GP14G	GP14G	GP14G	GP15G	GP15G

A grey background indicates the accessory must be assembled in the factory

GP2VN becomes GP2VNA if configured with a type A or B hydronic kit

Double safety valves

Ver	0800	0900	1000	1100	1200	1400	1600	1800	2000	2200	2400	2600	2800	3000	3200	3400	3600
° ,A,E,L	T6NRGLS1	T6NRGLS1	T6NRGLS1	T6NRGLS1	T6NRGLS1	T6NRGLS1	T6NRGLS1	T6NRGLS2	T6NRGLS3	T6NRGLS3	T6NRGLS3	T6NRGLS3	T6NRGLS4	T6NRGLS5	T6NRGLS5	T6NRGLS5	T6NRGLS5

A grey background indicates the accessory must be assembled in the factory

CONFIGURATOR

Field	Description
1,2,3	NRG
4,5,6,7	Size 0800, 0900, 1000, 1100, 1200, 1400, 1600, 1800, 2000, 2200, 2400, 2600, 2800, 3000, 3200, 3400, 3600
8	Operating field
X	Electronic thermostatic expansion valve (1)
Z	Low temperature electronic thermostatic valve (2)
9	Model
H	Heat pump
10	Heat recovery
°	Without heat recovery
D	With desuperheater (3)
11	Version
°	Standard
A	High efficiency
E	Silenced high efficiency
L	Standard silenced
12	Coils
°	Copper-aluminium
R	Copper pipes-copper fins
S	Copper pipes-Tinned copper fins
V	Copper pipes-Coated aluminium fins
13	Fans
°	Standard
J	Inverter
14	Power supply
°	400V ~ 3 50Hz with magnet circuit breakers
15,16	Integrated hydronic kit
00	Without hydronic kit
	Kit with n° 1 pump
PA	Pump A
PB	Pump B
PC	Pump C
PD	Pump D
PE	Pump E
PF	Pump F
PG	Pump G
PH	Pump H
PI	Pump I
PJ	Pump J (4)
	Pump n° 1 pump + stand-by pump
DA	Pump A + stand-by pump
DB	Pump B + stand-by pump
DC	Pump C + stand-by pump
DD	Pump D + stand-by pump
DE	Pump E + stand-by pump
DF	Pump F + stand-by pump
DG	Pump G + stand-by pump
DH	Pump H + stand-by pump
DI	Pump I + stand-by pump
DJ	Pump J + stand-by pump (4)
	Kit with storage tank and n° 1 pump
AA	Storage tank and pump A
AB	Storage tank and pump B
AC	Storage tank and pump C
AD	Storage tank and pump D
AE	Storage tank and pump E
AF	Storage tank and pump F
AG	Storage tank and pump G
AH	Storage tank and pump H
AI	Storage tank and pump I
AJ	Storage tank and pump J (4)
	Kit with storage tank and n° 1 pump + stand-by pump
BA	Storage tank with pump A + stand-by pump

Field	Description
BB	Storage tank with pump B + stand-by pump
BC	Storage tank with pump C + stand-by pump
BD	Storage tank with pump D + stand-by pump
BE	Storage tank with pump E + stand-by pump
BF	Storage tank with pump F + stand-by pump
BG	Storage tank with pump G + stand-by pump
BH	Storage tank with pump H + stand-by pump
BI	Storage tank with pump I + stand-by pump
BJ	Storage tank with pump J + stand-by pump (4)
	Kit with n° 1 inverter pump to fixed speed
IA	Pump A equipped with inverter device to work at fixed speed
IB	Pump B equipped with inverter device to work at fixed speed
IC	Pump C equipped with inverter device to work at fixed speed
ID	Pump D equipped with inverter device to work at fixed speed
IE	Pump E equipped with inverter device to work at fixed speed
IF	Pump F equipped with inverter device to work at fixed speed (5)
IG	Pump G equipped with inverter device to work at fixed speed (5)
IH	Pump H equipped with inverter device to work at fixed speed (5)
II	Pump I equipped with inverter device to work at fixed speed (5)
IJ	Pump J equipped with inverter device to work at fixed speed (6)
	Kit with n° 1 inverter pump + stand-by pump to fixed speed
JA	Pump A+stand-by pump, both equipped with inverter to work at fixed speed
JB	Pump B+stand-by pump, both equipped with inverter to work at fixed speed
JC	Pump C+stand-by pump, both equipped with inverter to work at fixed speed
JD	Pump D+stand-by pump, both equipped with inverter to work at fixed speed
JE	Pump E+stand-by pump, both equipped with inverter to work at fixed speed
JF	Pump F+stand-by pump, both equipped with inverter to work at fixed speed (5)
JG	Pump G+stand-by pump, both equipped with inverter to work at fixed speed (5)
JH	Pump H+stand-by pump, both equipped with inverter to work at fixed speed (5)
JI	Pump I+stand-by pump, both equipped with inverter to work at fixed speed (5)
JJ	Pump J+stand-by pump, both equipped with inverter to work at fixed speed (6)
	Kit with storage tank and n° 1 inverter pump to fixed speed
CA	Buffer tank + pump A, equipped with inverter to work at fixed speed
CB	Buffer tank + pump B, equipped with inverter to work at fixed speed
CC	Buffer tank + pump C, equipped with inverter to work at fixed speed
CD	Buffer tank + pump D, equipped with inverter to work at fixed speed
CE	Buffer tank + pump E, equipped with inverter to work at fixed speed
CF	Buffer tank + pump F, equipped with inverter to work at fixed speed (5)
CG	Buffer tank + pump G, equipped with inverter to work at fixed speed (5)
CH	Buffer tank + pump H, equipped with inverter to work at fixed speed (5)
CI	Buffer tank + pump I, equipped with inverter to work at fixed speed (5)
CJ	Buffer tank + pump J, equipped with inverter to work at fixed speed (6)
	Kit with storage tank and n° 1 pump + stand-by pump to fixed speed
KA	Buffer tank+pump A+stand-by pump, both with inverter to work at fixed speed
KB	Buffer tank+pump B+stand-by pump, both with inverter to work at fixed speed
KC	Buffer tank+pump C+stand-by pump, both with inverter to work at fixed speed
KD	Buffer tank+pump D+stand-by pump, both with inverter to work at fixed speed
KE	Buffer tank+pump E+stand-by pump, both with inverter to work at fixed speed
KF	Buffer tank+pump F+stand-by pump, both with inverter to work at fixed speed (5)
KG	Buffer tank+pump G+stand-by pump, both with inverter to work at fixed speed (5)
KH	Buffer tank+pump H+stand-by pump, both with inverter to work at fixed speed (5)
KI	Buffer tank+pump I+stand-by pump, both with inverter to work at fixed speed (5)
KJ	Buffer tank+pump J+stand-by pump, both with inverter to work at fixed speed (6)

(1) Water produced from 4 °C ÷ 20 °C

(2) Water produced from 8 °C ÷ -10 °C

(3) This option is not available with the Z operating field. The desuperheater must be intercepted in heating mode. In cooling mode, a water temperature no lower than 35°C must always be guaranteed on the heat exchanger inlet.

(4) For all configurations including pump J please contact the factory.

(5) Hydronic kit not available with sizes 0800 version °/L/A, 0900 version °, 1000 version °, 1800 version °.

(6) For all possible configurations which include the "J" pump please be in touch with Aermec. Hydronic kit is not available with sizes 0800 version °/L/A, 0900 version °, 1000 version °, 1800 version °.

PERFORMANCE SPECIFICATIONS

NRG H°

Size		0800	0900	1000	1100	1200	1400	1600	1800	2000	2200	2400	2600	2800	3000	3200	3400	3600	
Cooling performance 12 °C / 7 °C (1)																			
Cooling capacity	kW	200,5	220,2	238,5	292,2	325,7	353,6	381,6	456,8	531,9	561,5	591,1	705,6	749,2	824,6	859,3	895,1	925,3	
Input power	kW	72,8	83,7	95,6	107,5	123,5	144,5	160,8	179,5	199,4	219,3	239,1	249,8	277,9	299,4	317,7	334,1	354,4	
Cooling total input current	A	127,0	144,0	163,0	182,0	207,0	238,0	268,0	300,0	333,0	362,0	391,0	424,0	485,0	506,0	527,0	567,0	597,0	
EER	W/W	2,75	2,63	2,49	2,72	2,64	2,45	2,37	2,55	2,67	2,56	2,47	2,83	2,70	2,75	2,70	2,68	2,61	
Water flow rate system side	l/h	34503	37880	41031	50268	56029	60821	65615	78560	91483	96570	101650	121347	128839	141815	147773	153929	159128	
Pressure drop system side	kPa	25	30	35	45	45	47	29	42	50	49	47	53	60	69	73	75	79	
Heating performance 40 °C / 45 °C (2)																			
Heating capacity	kW	212,2	235,2	256,2	310,2	348,1	384,0	416,2	492,2	568,3	603,5	638,4	729,6	782,6	858,4	896,3	931,7	966,8	
Input power	kW	66,1	73,5	80,8	98,1	109,5	123,5	129,7	153,3	175,5	186,3	198,1	232,9	252,2	275,3	288,2	299,7	312,5	
Heating total input current	A	120,0	133,0	145,0	173,0	190,0	210,0	221,0	263,0	303,0	319,0	337,0	395,0	430,0	471,0	490,0	506,0	524,0	
COP	W/W	3,21	3,20	3,17	3,16	3,18	3,11	3,21	3,21	3,24	3,24	3,22	3,13	3,10	3,12	3,11	3,11	3,09	
Water flow rate system side	l/h	36823	40823	44470	53838	60421	66654	72264	85444	98663	104778	110847	126695	135884	149044	155628	161773	167874	
Pressure drop system side	kPa	29	36	42	53	54	58	37	52	60	60	58	58	66	76	81	83	88	

(1) Data EN 14511:2022; Heat exchanger water (services side) 12°C / 7°C; outside air 35°C

(2) Data EN 14511:2022; System side water heat exchanger 40 °C / 45 °C; Outside air 7 °C d.b. / 6 °C w.b.

NRG HL

Size		0800	0900	1000	1100	1200	1400	1600	1800	2000	2200	2400	2600	2800	3000	3200	3400	3600	
Cooling performance 12 °C / 7 °C (1)																			
Cooling capacity	kW	194,9	231,4	252,7	283,9	335,9	367,7	399,5	467,1	515,0	568,3	599,3	684,6	752,3	804,8	836,8	889,9	919,8	
Input power	kW	73,7	78,6	88,8	107,7	118,0	136,6	154,7	175,4	203,9	213,7	232,1	255,0	275,5	305,5	325,1	334,6	353,5	
Cooling total input current	A	125,0	136,0	153,0	179,0	196,0	222,0	249,0	285,0	331,0	346,0	374,0	420,0	457,0	506,0	528,0	540,0	568,0	
EER	W/W	2,65	2,94	2,85	2,64	2,85	2,69	2,58	2,66	2,53	2,66	2,58	2,69	2,73	2,63	2,57	2,66	2,60	
Water flow rate system side	l/h	33540	39819	43473	48838	57788	63245	68702	80332	88566	97728	103054	117728	129370	138391	143907	153027	158170	
Pressure drop system side	kPa	23	33	34	39	45	47	33	39	41	49	35	51	59	64	67	75	70	
Heating performance 40 °C / 45 °C (2)																			
Heating capacity	kW	209,6	244,9	268,8	305,3	357,3	394,2	431,7	502,3	558,0	611,4	647,2	717,8	788,1	844,0	880,6	933,5	969,8	
Input power	kW	64,6	76,2	83,3	95,6	111,1	123,9	131,4	152,8	170,0	186,9	199,5	227,5	249,8	267,9	280,7	297,4	310,8	
Heating total input current	A	115,0	134,0	147,0	165,0	188,0	207,0	219,0	257,0	288,0	313,0	333,0	378,0	416,0	447,0	466,0	491,0	512,0	
COP	W/W	3,24	3,22	3,23	3,19	3,22	3,18	3,29	3,29	3,28	3,27	3,24	3,15	3,16	3,15	3,14	3,14	3,12	
Water flow rate system side	l/h	36369	42513	46657	52988	62021	68420	74962	87217	96884	106143	112386	124645	136849	146552	152908	162100	168406	
Pressure drop system side	kPa	28	39	40	47	53	56	40	47	51	60	42	57	66	71	75	84	80	

(1) Data EN 14511:2022; Heat exchanger water (services side) 12°C / 7°C; outside air 35°C

(2) Data EN 14511:2022; System side water heat exchanger 40 °C / 45 °C; Outside air 7 °C d.b. / 6 °C w.b.

NRG HA

Size		0800	0900	1000	1100	1200	1400	1600	1800	2000	2200	2400	2600	2800	3000	3200	3400	3600	
Cooling performance 12 °C / 7 °C (1)																			
Cooling capacity	kW	200,5	236,4	258,7	292,2	344,0	378,0	412,2	480,7	532,0	584,8	618,3	700,8	768,8	824,7	859,0	911,3	943,6	
Input power	kW	71,4	78,5	88,2	105,8	117,2	134,5	151,4	172,4	196,2	210,0	227,1	245,1	271,0	296,0	314,1	327,9	345,4	
Cooling total input current	A	127,0	141,0	157,0	182,0	201,0	226,0	251,0	289,0	333,0	351,0	377,0	424,0	462,0	509,0	529,0	545,0	571,0	
EER	W/W	2,81	3,01	2,93	2,76	2,94	2,81	2,72	2,79	2,71	2,78	2,72	2,86	2,84	2,79	2,73	2,78	2,73	
Water flow rate system side	l/h	34505	40669	44506	50268	59178	65028	70879	82668	91485	100578	106317	120517	132216	141823	147725	156722	162264	
Pressure drop system side	kPa	24	33	34	39	45	47	33	39	42	50	35	53	61	67	70	79	74	
Heating performance 40 °C / 45 °C (2)																			
Heating capacity	kW	214,2	249,2	273,9	311,8	364,1	404,2	439,5	510,6	568,3	624,2	661,5	726,3	796,9	854,6	892,3	944,8	982,2	
Input power	kW	65,5	76,7	84,1	96,3	111,6	125,5	132,9	153,9	171,9	189,2	201,7	229,0	250,4	268,2	280,9	299,3	312,3	
Heating total input current	A	119,0	139,0	152,0	170,0	195,0	215,0	227,0	265,0	298,0	325,0	344,0	389,0	428,0	458,0	477,0	506,0	526,0	
COP	W/W	3,27	3,25	3,25	3,24	3,26	3,22	3,31	3,32	3,31	3,30	3,28	3,17	3,18	3,19	3,18	3,16	3,15	
Water flow rate system side	l/h	37179	43255	47538	54127	63192	70158	76308	88642	98663	108366	114875	126116	138372	148390	154943	164062	170550	
Pressure drop system side	kPa	29	40	41	49	55	58	41	49	53	62	44	58	67	73	77	86	82	

(1) Data EN 14511:2022; Heat exchanger water (services side) 12°C / 7°C; outside air 35°C

(2) Data EN 14511:2022; System side water heat exchanger 40 °C / 45 °C; Outside air 7 °C d.b. / 6 °C w.b.

Size		0800	0900	1000	1100	1200	1400	1600	1800	2000	2200	2400	2600	2800	3000	3200	3400	3600	
Fans: J																			
SEER - 12/7 (EN14825: 2018) (1)																			
SEER	°	W/W	3,91	4,03	3,76	4,01	3,91	3,74	3,72	3,92	4,10	-	-	-	-	-	-	-	
	A	W/W	4,13	4,47	4,22	4,21	4,48	4,13	4,21	4,29	4,27	4,57	4,58	4,56	4,55	4,56	4,55	4,55	4,55
	E	W/W	4,48	4,70	4,65	4,49	4,69	4,49	4,73	4,76	4,56	4,68	4,65	4,76	4,76	4,74	4,68	4,69	4,64
	L	W/W	4,08	4,38	4,31	4,23	4,49	4,33	4,17	4,32	4,24	4,57	4,57	4,58	4,61	4,56	4,56	4,57	4,56
Seasonal efficiency	°	%	153,54	158,21	147,58	157,44	153,60	146,56	145,75	153,87	160,99	-	-	-	-	-	-	-	
	A	%	162,28	175,77	165,92	165,53	176,30	162,21	165,54	168,43	167,63	179,84	180,02	179,30	179,05	179,25	179,11	179,12	179,03
	E	%	176,01	184,84	182,87	176,49	184,43	176,41	186,08	187,33	179,21	184,21	182,92	187,25	187,42	186,77	184,02	184,64	182,40
	L	%	160,02	172,22	169,30	166,37	176,46	170,12	163,61	169,99	166,45	179,96	179,77	180,32	181,27	179,57	179,44	179,67	179,24
SEER - 23/18 (EN14825: 2018) (2)																			
SEER	°	W/W	4,53	4,62	4,30	4,53	4,48	4,26	4,26	4,36	4,53	4,68	4,67	5,20	5,04	5,05	4,95	5,04	4,89
	A	W/W	4,82	5,14	4,88	4,83	5,05	4,68	4,77	4,78	4,70	4,74	4,81	5,32	5,32	5,33	5,34	5,33	5,33
	E	W/W	5,22	5,39	5,29	5,11	5,24	5,05	5,33	5,29	5,01	5,07	5,11	5,49	5,49	5,47	5,39	5,40	5,34
	L	W/W	4,86	5,04	4,92	4,80	5,00	4,85	4,70	4,80	4,72	4,81	4,84	5,12	5,16	5,10	5,09	5,10	5,09
Seasonal efficiency	°	%	178,23	181,99	169,18	178,03	176,17	167,49	167,32	171,54	178,15	184,08	183,60	205,12	198,46	198,95	195,09	198,65	192,44
	A	%	189,87	202,58	192,30	190,02	199,05	184,16	187,89	188,04	185,13	186,42	189,27	209,91	209,61	210,19	210,50	210,33	210,27
	E	%	205,68	212,67	208,75	201,59	206,78	199,04	210,37	208,55	197,30	199,90	201,24	216,49	216,66	215,99	212,50	213,20	210,64
	L	%	191,27	198,67	193,92	188,82	196,81	191,05	185,11	189,15	185,81	189,25	190,57	201,98	203,21	201,03	200,73	201,14	200,54
UE 813/2013 performance in average ambient conditions (average) - 35 °C - Pdesignh ≤ 400 kW (3)																			
Pdesignh	°	kW	-	-	-	-	-	-	-	-	-	-	-	-	-	-	-	-	
	A	kW	3,75	3,72	3,74	3,65	3,72	3,69	3,84	3,87	3,90	3,92	3,98	3,85	3,79	3,79	3,78	3,78	3,76
	E	kW	3,98	3,87	3,91	3,92	3,89	3,93	4,04	4,03	4,08	4,08	4,13	4,01	4,00	3,98	3,95	3,93	3,90
	L	kW	3,94	3,86	3,89	3,90	3,88	4,00	4,05	4,08	4,09	4,09	4,13	3,97	3,96	3,93	3,90	3,88	3,86
SCOP	°	W/W	3,85	3,81	3,86	3,82	3,85	3,87	3,94	3,98	4,02	3,99	4,06	3,91	3,90	3,89	3,87	3,85	3,84
	A	W/W	147,19	145,69	146,78	143,12	145,88	144,64	150,61	151,86	152,83	153,82	156,25	151,09	148,73	148,69	148,14	148,30	147,30
	E	W/W	156,18	151,63	153,29	153,96	152,61	154,02	158,78	158,12	160,03	160,11	162,27	157,54	157,00	156,15	155,07	154,33	152,86
	L	W/W	154,67	151,25	152,53	152,86	152,04	156,84	159,16	160,06	160,74	160,54	162,33	155,93	155,35	154,31	152,99	152,26	151,57
ηsh	°	%	151,15	149,30	151,53	149,80	151,00	151,92	154,77	156,17	157,80	156,44	159,42	153,41	152,88	152,46	151,65	151,15	150,49
	A	%	185	207	225	272	306	341	372	346	394	535	566	645	691	757	791	822	859
	E	%	187	215	237	273	317	354	387	352	394	547	582	637	698	748	781	827	866
	L	%	190	216	239	278	318	355	397	355	398	553	591	643	702	755	787	829	870
Pdesignh	°	kW	183	212	233	267	312	347	382	349	391	538	573	631	693	742	773	819	852
	A	kW	3,13	3,11	3,12	3,08	3,11	3,05	3,08	3,15	3,26	3,26	3,29	3,18	3,15	3,17	3,17	3,17	3,12
	E	kW	3,30	3,26	3,28	3,28	3,25	3,24	3,24	3,26	3,36	3,37	3,35	3,30	3,31	3,30	3,29	3,29	3,20
	L	kW	3,31	3,25	3,27	3,26	3,22	3,28	3,29	3,33	3,42	3,38	3,37	3,30	3,30	3,30	3,28	3,26	3,21
SCOP	°	W/W	3,19	3,20	3,23	3,18	3,20	3,19	3,15	3,22	3,31	3,28	3,28	3,20	3,21	3,21	3,20	3,21	3,18
	A	W/W	122,27	121,29	121,95	120,26	121,59	119,01	120,35	122,90	127,46	127,29	128,67	124,30	123,00	123,82	123,69	123,98	121,67
	E	W/W	129,05	127,35	128,02	128,24	126,95	126,45	126,66	127,60	131,34	131,91	130,84	128,88	129,31	129,14	128,59	128,77	125,11
	L	W/W	129,38	127,17	127,67	127,41	125,90	128,13	128,78	130,27	133,70	132,16	131,79	129,12	129,08	129,12	128,32	127,41	125,24
ηsh	°	%	124,44	124,94	126,12	124,20	125,05	124,58	123,06	125,71	129,24	128,27	128,14	124,91	125,29	125,42	125,07	125,42	124,38
	A	%	5,05	5,15	4,98	5,20	5,21	5,23	5,12	5,31	5,49	5,45	5,37	5,51	5,52	5,52	5,51	5,51	5,51
	E	%	5,34	5,76	5,59	5,54	5,85	5,69	5,67	5,79	5,66	5,85	5,87	5,52	5,53	5,53	5,53	5,53	5,52
	L	%	5,91	6,15	6,16	5,82	6,03	6,22	6,44	6,48	6,24	6,31	6,25	5,56	5,57	5,57	5,56	5,56	5,56
SEPR	°	W/W	5,38	5,72	5,70	5,51	5,69	5,87	5,66	5,85	5,69	5,96	5,88	5,51	5,52	5,52	5,51	5,51	5,51
	A	W/W	5,05	5,15	4,98	5,20	5,21	5,23	5,12	5,31	5,49	5,45	5,37	5,51	5,52	5,52	5,51	5,51	5,51
	E	W/W	5,34	5,76	5,59	5,54	5,85	5,69	5,67	5,79	5,66	5,85	5,87	5,52	5,53	5,53	5,53	5,53	5,52
	L	W/W	5,91	6,15	6,16	5,82	6,03	6,22	6,44	6,48	6,24	6,31	6,25	5,56	5,57	5,57	5,56	5,56	5,56

(1) Calculation performed with FIXED water flow rate and VARIABLE outlet temperature.

(2) Calculation performed with FIXED water flow rate.

(3) Efficiencies for low temperature applications (35 °C)

(4) Efficiencies for average temperature applications (55 °C)

ELECTRIC DATA

Size		0800	0900	1000	1100	1200	1400	1600	1800	2000	2200	2400	2600	2800	3000	3200	3400	3600	
Electric data																			
Maximum current (FLA)	°	A	162,2	180,5	198,8	234,5	262,4	290,3	318,1	371,7	425,3	453,2	481,1	542,5	588,3	641,9	669,8	697,7	725,5
	A,L	A	162,2	188,3	206,6	234,5	270,2	298,1	325,9	379,5	425,3	461,0	488,9	542,5	596,1	641,9	669,8	705,5	733,3
	E	A	170,0	196,1	214,4	242,3	278,0	305,9	341,5	395,1	440,9	476,6	504,5	558,1	611,7	657,5	685,4	721,1	748,9
Peak current (LRA)	°	A	365,6	421,7	440,0	696,8	724,7	752,6	780,4	834,1	887,7	915,5	943,4	1004,8	1050,6	1104,2	1132,1	1160,0	1187,8
	A,L	A	365,6	429,5	447,8	696,8	732,5	760,4	788,2	841,9	887,7	923,3	951,2	1004,8	1058,4	1104,2	1132,1	1167,8	1195,6
	E	A	373,4	437,3	455,6	704,6	740,3	768,2	803,8	857,5	903,3	938,9	966,8	1020,4	1074,0	1119,8	1147,7	1183,4	1211,2

Data calculated without hydronic kit and accessories.

GENERAL TECHNICAL DATA

Compressors

Size		0800	0900	1000	1100	1200	1400	1600	1800	2000	2200	2400	2600	2800	3000	3200	3400	3600		
Compressor																				
Type	° _{A,E,L}	type																	Scroll	
Compressor regulation	° _{A,E,L}	Type																	On-Off	
Number	° _{A,E,L}	no.	4	4	4	4	4	4	4	5	6	6	6	7	8	9	9	9	9	
Circuits	° _{A,E,L}	no.	2	2	2	2	2	2	2	2	2	2	3	3	3	3	3	3	3	
Refrigerant	° _{A,E,L}	type																	R32	
Refrigerant load circuit 1 (1)	°	kg	16,5	16,5	22,5	23,3	23,3	22,5	22,5	30,4	30,8	36,0	36,0	34,4	35,1	35,4	35,4	38,9	38,9	
	A,L	kg	13,0	22,0	20,0	20,0	28,0	28,0	29,3	33,0	43,9	40,0	41,0	34,4	39,6	44,1	44,1	44,1	44,1	44,6
	E	kg	21,8	28,5	29,3	27,5	29,3	34,9	42,0	51,0	53,6	56,3	51,8	48,9	48,9	50,6	50,6	52,4	53,4	
Refrigerant load circuit 2 (1)	°	kg	16,5	16,5	22,5	23,3	23,3	22,5	22,5	30,4	30,8	36,0	36,0	34,4	35,1	35,4	35,4	38,9	38,9	
	A,L	kg	13,0	22,0	22,0	20,0	28,0	28,0	29,3	33,0	43,9	40,0	41,0	34,4	39,6	44,1	44,1	44,1	44,1	44,6
	E	kg	21,8	28,5	29,3	27,5	29,3	34,9	42,0	51,0	53,6	56,3	51,8	48,9	48,9	50,6	50,6	52,4	53,4	
Refrigerant load circuit 3 (1)	°	kg	-	-	-	-	-	-	-	-	-	-	34,4	35,1	35,4	35,4	38,9	38,9		
	A,L	kg	-	-	-	-	-	-	-	-	-	-	34,4	39,6	44,1	44,1	44,1	44,1	44,6	
	E	kg	-	-	-	-	-	-	-	-	-	-	48,9	48,9	50,6	50,6	52,4	53,4		
Potential global heating	° _{A,E,L}	GWP																	675kgCO ₂ eq	

(1) The load indicated in the table is an estimated and preliminary value. The final value of the refrigerant load is indicated on the unit's technical label. For further information contact the office.

System side heat exchanger

Size		0800	0900	1000	1100	1200	1400	1600	1800	2000	2200	2400	2600	2800	3000	3200	3400	3600	
System side heat exchanger																			
Type	° _{A,E,L}	type																	Brazed plate
Number	° _{A,E,L}	no.	1	1	1	1	1	1	1	1	1	1	2	2	2	2	2	2	2

Integrated hydronic kit: 00

Hydraulic connections

Connections (in/out)	° _{A,E,L}	Type	Grooved joints																
Sizes (in/out)	°	Ø	3"	3"	3"	3"	3"	4"	4"	4"	4"	4"	5"	5"	5"	5"	5"	5"	5"
	A,L	Ø	3"	3"	3"	3"	3"	4"	4"	4"	4"	5"	5"	5"	5"	5"	5"	5"	5"
	E	Ø	3"	3"	3"	3"	4"	4"	4"	4"	4"	5"	5"	5"	5"	5"	5"	5"	5"

Fans

Size		0800	0900	1000	1100	1200	1400	1600	1800	2000	2200	2400	2600	2800	3000	3200	3400	3600	
Fans: °																			
Fan																			
Type	° _{A,E,L}	type																	Axial
Number	°	no.	4	4	4	6	6	6	6	8	10	10	10	14	14	16	16	16	16
	A,L	no.	4	6	6	6	8	8	8	10	10	12	12	14	16	16	16	18	18
	E	no.	6	8	8	8	10	10	12	14	14	16	16	18	20	20	20	22	22
Fan motor	° _A	type																	Asynchronous
	E,L	type																	Asynchronous with phase cut
	°	m ³ /h	82398	82398	82424	123596	123596	123561	123561	164866	205969	205969	205969	288399	288399	329594	329594	329598	329598
Air flow rate	A	m ³ /h	82403	123609	123609	123605	164779	164779	164779	205996	205998	247152	247152	288414	329556	329556	329556	370819	370819
	E	m ³ /h	102378	136491	136491	136491	170613	170613	204757	238871	238871	272982	272982	315634	349835	349835	349835	383943	383943
	L	m ³ /h	68237	102348	102348	102356	136528	136528	136528	170617	170614	204825	204825	238801	273004	273004	273004	307010	307010

Sound data

Size		0800	0900	1000	1100	1200	1400	1600	1800	2000	2200	2400	2600	2800	3000	3200	3400	3600	
Sound data calculated in cooling mode (1)																			
Sound power level	°	dB(A)	90,5	90,5	90,5	92,3	92,4	92,5	92,6	93,8	94,7	94,7	94,8	96,5	96,6	97,1	97,1	97,2	97,3
	A	dB(A)	90,5	92,2	92,2	92,3	93,6	93,6	93,7	94,6	94,7	95,4	95,5	96,5	97,1	97,1	97,1	97,6	97,7
	E	dB(A)	85,2	86,2	86,2	87,0	88,3	88,8	89,7	90,1	90,2	90,9	91,2	92,2	92,5	92,6	92,8	93,3	93,5
	L	dB(A)	83,5	84,7	84,8	85,8	87,2	87,8	88,3	88,9	89,0	89,8	90,1	91,0	91,3	91,4	91,7	92,2	92,4
	°	dB(A)	58,4	58,4	58,4	60,0	60,1	60,2	60,4	61,3	62,1	62,2	62,2	63,7	63,7	64,1	64,2	64,3	64,3
	A	dB(A)	58,4	59,9	59,9	60,0	61,2	61,2	61,3	62,1	62,1	62,8	62,8	63,7	64,1	64,1	64,2	64,6	64,6
Sound pressure level (10 m)	E	dB(A)	52,9	53,8	53,8	54,6	55,7	56,3	57,0	57,3	57,4	57,9	58,2	59,1	59,3	59,4	59,7	60,0	60,2
	L	dB(A)	51,4	52,5	52,5	53,5	54,8	55,4	55,9	56,4	56,5	57,1	57,4	58,2	58,4	58,5	58,8	59,1	59,4

(1) Sound power calculated on the basis of measurements made in accordance with UNI EN ISO 9614-2, as required for Eurovent certification. Sound pressure (cold functioning) measured in free field, 10m away from the unit external surface (in compliance with UNI EN ISO 3744).

DIMENSIONS

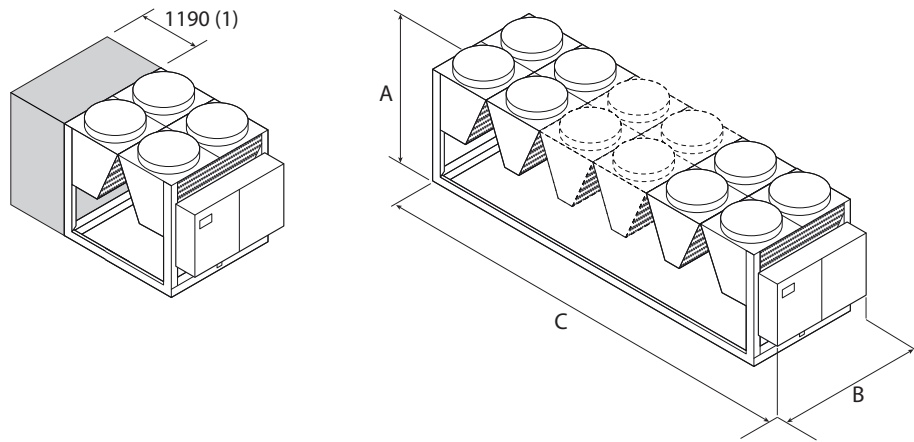

(1) Additional module needed to contain the hydronic kit with "accumulation" option in sizes:
 NRG 0800H°, 0900H°, 1000H°
 NRG 0800HL
 NRG 0800HA

Size		0800	0900	1000	1100	1200	1400	1600	1800	2000	2200	2400	2600	2800	3000	3200	3400	3600	
Integrated hydronic kit: 00																			
Dimensions and weights																			
A	°A,E,L	mm	2450	2450	2450	2450	2450	2450	2450	2450	2450	2450	2450	2450	2450	2450	2450	2450	2450
B	°A,E,L	mm	2200	2200	2200	2200	2200	2200	2200	2200	2200	2200	2200	2200	2200	2200	2200	2200	2200
	°	mm	2780	2780	2780	3970	3970	3970	3970	5160	5160	6350	6350	6350	8730	8730	9920	9920	9920
C	A,L	mm	2780	3970	3970	3970	5160	5160	5160	6350	6350	7540	7540	8730	9920	9920	9920	11110	11110
	E	mm	3970	5160	5160	5160	6350	6350	7540	8730	8730	9920	9920	11110	12300	12300	12300	13490	13490
Weights																			
	°	kg	2350	2385	2385	3040	3185	3335	3585	4425	5200	5430	5540	7035	7310	8070	8185	8410	8520
Empty weight	A,L	kg	2350	2850	2860	3045	3770	3930	4170	4905	5230	5850	5880	7035	7800	8105	8220	8840	8930
	E	kg	2835	3460	3465	3650	4405	4405	4995	5800	6100	6795	6915	7980	8810	9090	9200	9845	9970
Integrated hydronic kit: AA, AB, AC, AD, AE, AF, AG, AH, AI, AJ, BA, BB, BC, BD, BE, BF, BG, BH, BI, BJ, CA, CB, CC, CD, CE, CF, CG, CH, CI, CJ, KA, KB, KC, KD, KE, KF, KG, KH, KI, KJ																			
Dimensions and weights																			
A	°A,E,L	mm	2450	2450	2450	2450	2450	2450	2450	2450	2450	2450	2450	2450	2450	2450	2450	2450	2450
B	°A,E,L	mm	2200	2200	2200	2200	2200	2200	2200	2200	2200	2200	2200	2200	2200	2200	2200	2200	2200
	°	mm	3970	3970	3970	3970	3970	3970	3970	5160	5160	6350	6350	8730	8730	9920	9920	9920	9920
C	A,L	mm	3970	3970	3970	3970	5160	5160	5160	6350	6350	7540	7540	8730	9920	9920	9920	11110	11110
	E	mm	3970	5160	5160	5160	6350	6350	7540	8730	8730	9920	9920	11110	12300	12300	12300	13490	13490
Weights																			
	°	kg	3350	3380	3380	3770	3915	4065	4315	5185	6000	6230	6345	7725	8005	8760	8875	9100	9210
Empty weight	A,L	kg	3330	3585	3595	3780	4530	4685	4925	5710	6035	6810	6840	7725	8005	8760	8875	9100	9210
	E	kg	3570	4215	4225	4180	5165	5165	5955	6765	7110	7680	7800	8875	9705	9985	10100	10745	10865
Integrated hydronic kit: DA, DB, DC, DD, DE, DF, DG, DH, DI, DJ, IA, IB, IC, ID, IE, IF, IG, IH, II, IJ, JA, JB, JC, JD, JE, JF, JG, JH, JI, JJ, PA, PB, PC, PD, PE, PF, PG, PH, PI, PJ																			
Dimensions and weights																			
A	°A,E,L	mm	2450	2450	2450	2450	2450	2450	2450	2450	2450	2450	2450	2450	2450	2450	2450	2450	2450
B	°A,E,L	mm	2200	2200	2200	2200	2200	2200	2200	2200	2200	2200	2200	2200	2200	2200	2200	2200	2200
	°	mm	2780	2780	2780	3970	3970	3970	3970	5160	5160	6350	6350	8730	8730	9920	9920	9920	9920
C	A,L	mm	2780	3970	3970	3970	5160	5160	5160	6350	6350	7540	7540	8730	9920	9920	9920	11110	11110
	E	mm	3970	5160	5160	5160	6350	6350	7540	8730	8730	9920	9920	11110	12300	12300	12300	13490	13490
Weights																			
	°	kg	2780	2810	2810	3465	3610	3760	4010	4790	5560	5795	5905	7420	7695	8450	8565	8790	8900
Empty weight	A,L	kg	2780	3280	3285	3475	4135	4290	4535	5270	5595	6210	6245	7420	8185	8485	8600	9220	9310
	E	kg	3200	3825	3830	4015	4770	4770	5360	6165	6465	7160	7280	8360	9190	9470	9585	10230	10350

Aermec reserves the right to make any modifications deemed necessary.
 All data is subject to change without notice. Aermec does not assume responsibility or liability for errors or omissions.

Aermec S.p.A.
 Via Roma, 996 - 37040 Bevilacqua (VR) - Italia
 Tel. 0442633111 - Telefax 044293577
 www.aermec.com